

C.I.P.

50 Browning

Country of Origin: US

TAB. I

Date 95-05-31

Revision 10-05-26

Alternative Names: 12,7 x 99

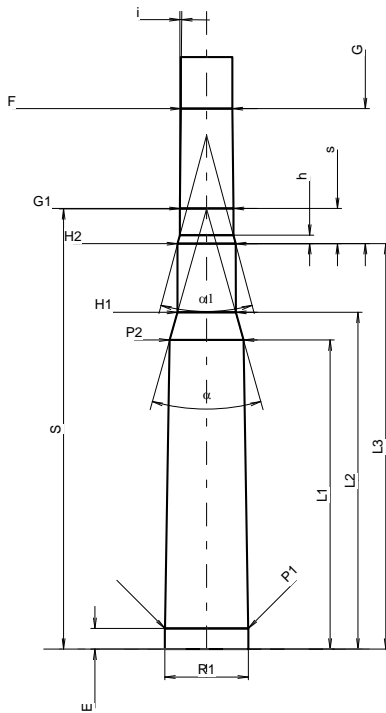
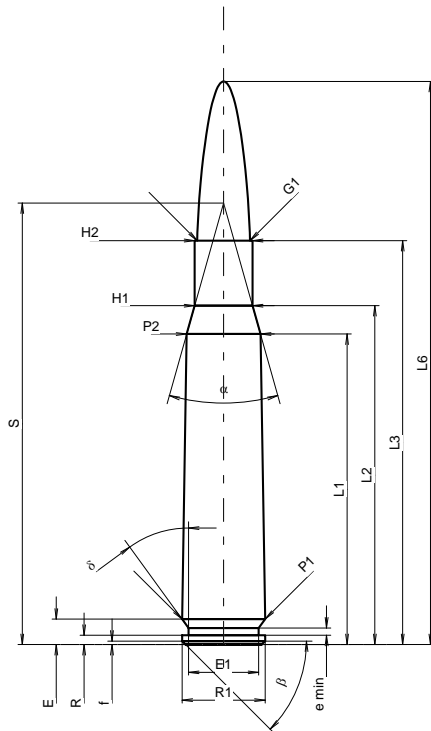

Scale 1:1.86

Dimensions in << mm >>
Dimensions and Tolerances for Proof Barrels
see Appendix CR 1.

CARTRIDGE MAXI

Lengths

L1 ¹⁾	=	76.34	-0.20
L2 ¹⁾	=	83.30	-0.20
L3 ¹⁾	=	99.31	
L4	=		
L5	=		
L6	=	138.43	

Case Head

R	=	2.26	
R1	=	20.42	
R3	=		
E	=	6.23	
E1	=	17.27	
e min	=	1.80	
delta	=	36°	
f	=	0.84	
beta	=	45°	

Powder Chamber

P1	=	20.42	
P2 ¹⁾ *	=	18.14	-0.20

Junction Cone

alpha [*]	=	31°28'	
S [*]	=	108.54	
r1 min	=		
r2	=		

Collar

H1 [*]	=	14.22	
H2 ¹⁾	=	14.22	

Projectile

G1 ¹⁾ *	=	12.98	
G2	=		
F	=		
L3+G ¹⁾	=	132.50	

Pressures (Energies)

Method Transducer

Pmax	=	3700 bar	
PK	=	4255 bar	
PE	=	4625 bar	
M	=	25.00	
EE	=	15000 Joule	

Miscellaneous Dimensions

Fe ¹⁾³⁾	=	0.15	
delta L	=	0.28	

CHAMBER MINI

Lengths

L1	=	76.02	
L2	=	82.82	
L3 ¹⁾	=	99.70	

Breech

R	=		
R1	=	20.52	
R2	=		
R3	=		
r	=		

Powder Chamber

E	=	5.08	
P1 ¹⁾	=	20.45	
P2 [*]	=	18.16	

Junction Cone

alpha ¹⁾ *	=	31°28'	
S [*]	=	108.25	
r1 max	=		
r2	=		

Collar

H1 [*]	=	14.33	
H2 ¹⁾	=	14.28	

Commencement of Rifling

G1 ¹⁾ *	=	13.16	
G ¹⁾	=	33.19	
alpha l	=	30°	
h	=	2.09	
s	=	8.64	
i ¹⁾ *	=	0°34'59"	
w	=		

Barrel

F ¹⁾ *	=	12.66	
Z ¹⁾	=	12.93	

Grooves

b	=	3.43	
N	=	8	
u	=	381.00	
Q	=	129.63	mm ²

Notes: 1) Check for safety reasons
3) Headspace on Shoulder
* Basic dimensions